

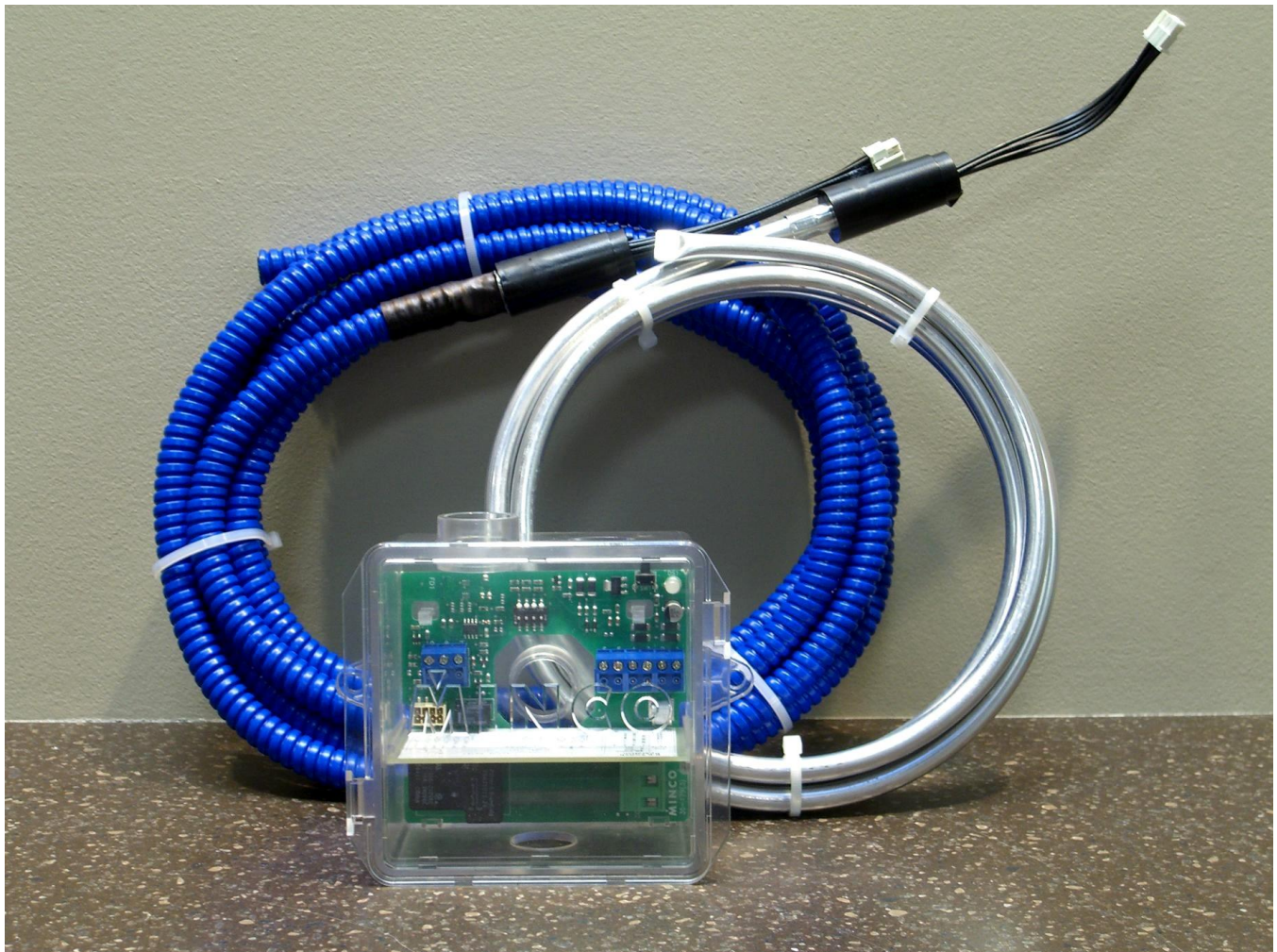

AS570
Chill-Out Combination Sensor
Installation and Operating Instructions



Description:

Model AS570 is a combination sensor, which includes a low-temperature cutout controller with an integrated resistance averaging sensor, one 12A 240VAC power relay, and one 1A signal relay. Individual temperature sensors spaced throughout the length of the sensor housing allow the device to detect temperatures below the adjustable setpoint within any 12" segment. In the event of an alarm condition, the relay contacts will default to the failed condition increasing the safety of the device. Furthermore, the solid state design and rugged 3/8" diameter tubing eliminate concerns of traditional low-limit controllers by eliminating gas leaks or kinking of the capillary during installation. The sensor housing is available in either aluminum tubing or flexible plenum-rated PVC coated galvanized steel armor. The high capacity relay and signal relay allow the device to be further tailored to meet the needs of any installation. The AS570 series controls are designed for use only as operating controls. Where an operating failure would result in personal injury and/or loss of property, it is the responsibility of the installer to add devices (safety, limit controls) or systems (alarm, supervisory systems) that protect against, or warn of, control failure.

Low-Limit Cutout Specifications:

- Switching Temperature:** 38°F factory pre-set, user adjustable from 30°F to 44°F
Setpoint Accuracy: ±0.9°F (±0.5°C) typical from 18°F (-7.8°C) to 131°F (55°C)
±1.4°F (±0.8°C) typical from -22°F (-30°C) to 158° (70°C)
Power Requirements: 24VAC or 24VDC ± 10%, Class 2, SELV <15W
120mA typical current draw
Relay Rating: **Standard Power Relay, SPDT**

Contact	Normally Open		Normally Closed	
	120 VAC	240 VAC	120 VAC	240 VAC
AC Motor Voltage	120 VAC	240 VAC	120 VAC	240 VAC
AC Full Load Amp	12	8	6	3
AC Locked Rotor Amp	96	30	36	18
Pilot Duty	125 VA	125 VA	125 VA	125 VA

Rated number of operations:

Normally Open – 100,000

Normally Closed – 50,000

Pilot Duty – 30,000

Standard Signal Relay, SPDT

1A @ 24VDC – SELV

- Sensor Case Length:** 8 feet standard for bendable aluminum tubing,
17 feet standard for flexible plenum-rated galvanized steel armor,
lengths of up to 50 feet are available

Connection: Signal terminal blocks: Accepts wires 14 to 24 AWG
Power relay terminal block: Accepts wires 12 to 24 AWG

Operating Temperature: -22°F (-30°C) to 158° (70°C) *

Storage Temperature: -40°F (-40°C) to 176°F (80°C)

Averaging Sensor Specifications:

Sensing Element Type: 4 thin-film elements wired in a series-parallel configuration:
PF:1000 Ω Platinum RTD (TCR = .00385 Ω/ Ω /°C, 1000 Ω at 0°C)
(TCR = 3.85 Ω /°C, 2.14 Ω /°F)

Sensor Tolerance: DIN Class B sensing elements = .12% @ 1000 Ω

* UL listed operating temperature: 18°F (-7.8°C) to 131°F (55°C)

Description of Functionality:

Both the power relay and signal relay are energized on power-up of the controller so the normally closed (NC) contacts are opened and the normally open (NO) contacts are closed. If the temperature falls below the setpoint over any 12" segment of the sensing element for more than 5 seconds, the device will go into its alarm state and both relays are de-energized. The status LED will indicate the state of the controller. During normal operation, the LED will be green, and during an alarm condition, the LED will be red. When configured as latching (Dip switch 4 set to off), the relay and LED will continue to indicate an alarm even if the temperature were to rise above the setpoint. (See section on Latching/Non-Latching) The system can be reset by pressing the reset switch until the LED changes back to green. The controller saves its state when the alarm condition changes, which causing it to resume to the previous state in the event of a temporary power loss. Because of this, the system will not reset when the power is cycled. The device will automatically reset when configured as non-latching (Dip switch 4 set to on).

Latching vs. Non-Latching:

The AS570 is initially configured in latching mode. In latching mode, if an alarm has occurred, even if the temperature rises above the setpoint, the device will not reset automatically. In this case, the device can be reset by pressing the local reset switch or external reset switch (if available). When resetting the device, hold the local or external reset switch for two seconds.

In order to configure the device in non-latching mode, dip switch 4 must be set to ON. This means that if the alarm has been tripped, once the temperature rises above the setpoint plus the deadband, the alarm will automatically reset. This resets both relays to their normal operation state as well as returning the LED to the green condition. The dead-band of the AS570 is 3.6°F (2°C). The device will automatically reset and resume normal operation when the temperature rises to 3.6°F above the selected setpoint.

Setpoint Adjustment:

The setpoint of the AS570 is adjustable from 30°F to 44°F in 2°F increments. To adjust the setpoint, set Dip Switches 1–3 on the surface of the board to the proper configuration for the desired setpoint (see figures 1 and 2).

Non-Latching (Auto Reset)				Latching (Manual Reset)					
Temp (°F)	Switch Setting				Temp (°F)	Switch Setting			
	1	2	3	4		1	2	3	4
30	☐	☐	☐	☐	30	☐	☐	☐	☐
32	☐	☐	☐	☐	32	☐	☐	☐	☐
34	☐	☐	☐	☐	34	☐	☐	☐	☐
36	☐	☐	☐	☐	36	☐	☐	☐	☐
38	☐	☐	☐	☐	38	☐	☐	☐	☐
40	☐	☐	☐	☐	40	☐	☐	☐	☐
42	☐	☐	☐	☐	42	☐	☐	☐	☐
44	☐	☐	☐	☐	44	☐	☐	☐	☐

Figure 1 – Setpoint Adjustment Diagram

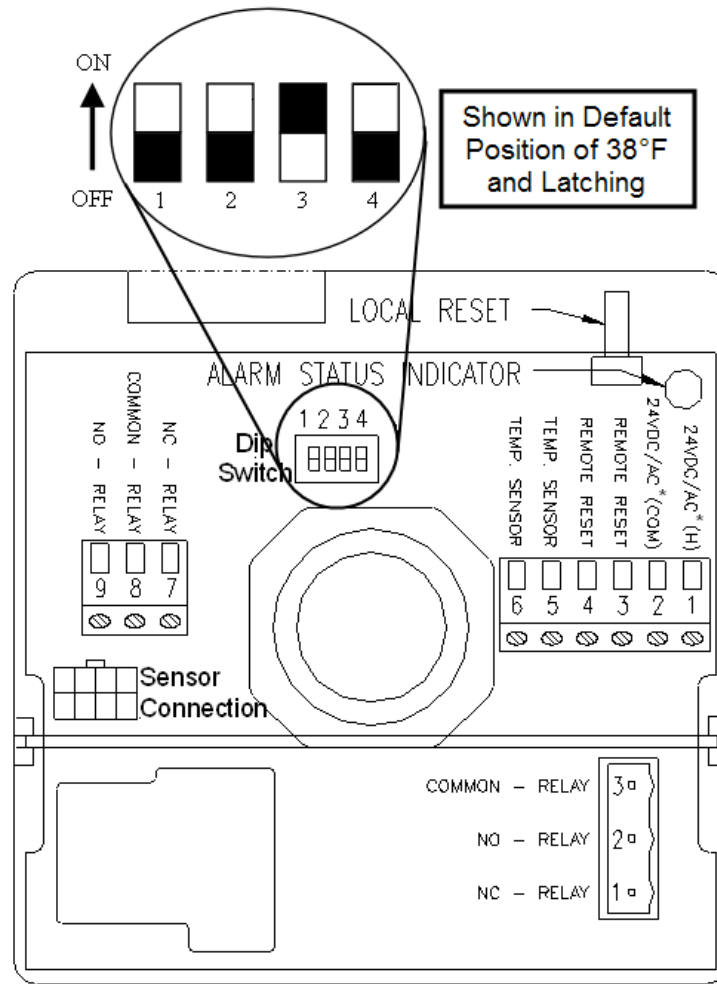

*Power supply - Class 2, SELV <15W

Figure 2 – Setpoint Adjustment Diagram

Additional Safety Information:

UL 60730 Listed – File E211718

CE Certified:

Safety – EN60730

Immunity – EN61000-4-3, EN61000-4-6

Emissions – EN61000-6-3, EN60730-1, EN55011 Group 1 Class B, FCC Part 15 Subpart B Class B

Information	Description
Purpose of control	Sensing Control
Construction of control and whether the control is electronic	Electronic Independently mounted control
Method of Mounting control	Mounted using two tabs ¼" diameter holes.
TYPE 1 or TYPE 2 action	TYPE 1
Additional features of Type 1 or Type 2 action	Type 1.B
Extent of any sensing element	Up to 100 feet
Pollution Situation	Pollution degree 2
RATED IMPULSE VOLTAGE	4000
Using Conduit	All AS570 Series controllers accept 3/8 in. trade size flexible metal conduit. 1- Feed the cables through the field supplied conduit. 2- Attach conduit to integral fittings.

Installation Instructions:

Mounting

Unlike traditional low-temperature cutout devices, the Chill-Out combination sensor can be installed in virtually any manner to meet the needs of your application. The sensing element and controller are not sensitive to the mounting direction, nor does the controller need to be located in a warmer ambient temperature than the sensing element or setpoint.

The AS570 enclosure is equipped with a sensor connection hole in both the side and the bottom for greater mounting flexibility. The bottom hole may be used to feed the sensor tubing directly into the duct from the enclosure when mounted to the surface of the duct. The side hole may be used if the tubing needs to enter the duct from a location other than where the enclosure is mounted.

Typical installation in an Air Handler Unit (AHU)

1. Before attempting to install the device, determine where the device will be located. Avoid areas subject to excessive electrical noise, vibration and direct sunlight. The device must be mounted in an accessible location. In most AHU's, the sensing element is usually located on the downstream side of the coil. Once you have determined where the unit will be installed, drill or cut a hole in the panel board as follows:

Models mounted using bottom opening - .85" to .9"

Models mounted using side opening - .4" to .45" for aluminum sensors, .55" to .60" for flexible PVC sensors

2. Feed the tubing plug insert through the hole from the inside of the duct. Fit the insert into the desired opening in the enclosure and make sure it snaps into place. See figure 3, below. Secure the enclosure to the panel using the two 0.250" holes located in the mounting ears on the bottom of the box. The enclosure should be mounted such that the mounting ears are to the sides and the high-voltage portion of the controller should be towards the bottom. This orientation can be seen in figures 9 and 10.

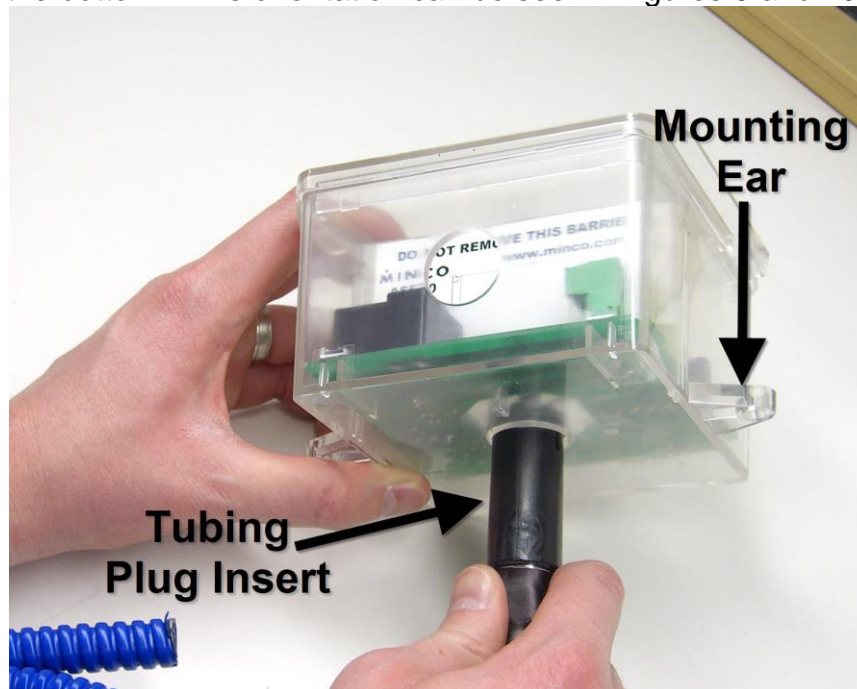

Figure 3 – Connecting insert to enclosure

3. Carefully remove the cover of the utility box, using a tool such as a screwdriver or pliers if necessary, and locate the sensor connector as shown in figure 9 on page 10. Connect the wire harness of the sensor into the sensor connection on the board until it snaps in place.
4. When securing the sensing element, use one of the methods shown below in figure 4. Secure sensing element away from sharp or abrasive objects or surfaces. Vibration and sharp or abrasive objects can damage the element. For best coverage of the coil and operation of the device, use the method below. Other mounting arrangements may be used, however this may cause issues due to the stratification of air in the duct. The element should be attached to the panel or coil with the use of wire ties or mounting brackets. If there is any remaining length of the element that is not needed, it may be coiled into a loop and placed where convenient inside the duct.

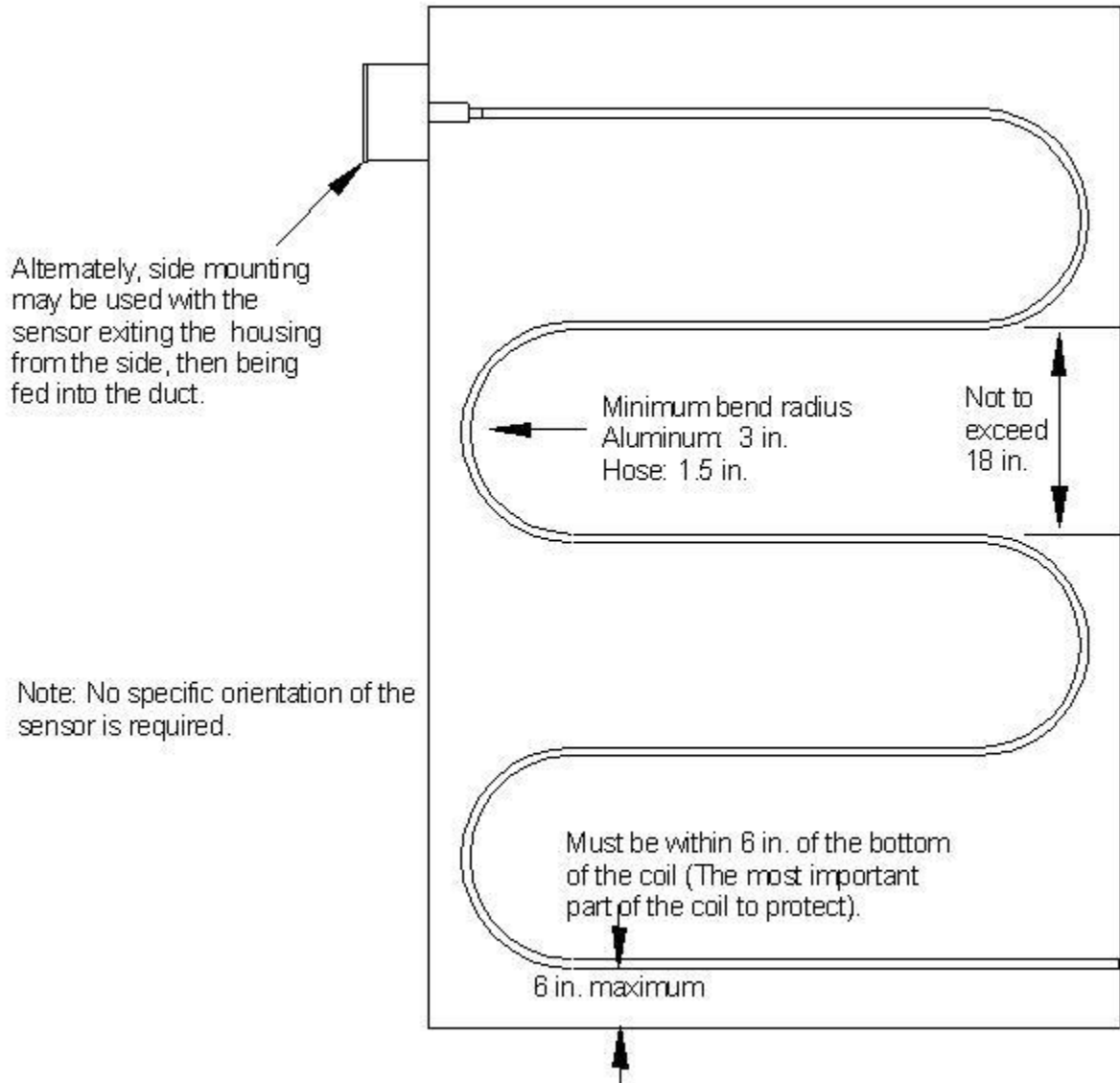

Figure 4 – Ideal Sensing Element Installation

Note: The size of duct work or air handling unit system in which the device is being installed may require more than one control to adequately protect the system. Be careful when drilling holes or driving screws while mounting sensing elements to avoid puncturing or damaging hydronic coils.

Electrical Connections

All electrical connections should be made in accordance with the National Electrical Code and local regulations. The AS570 must be powered by a class 2 limited energy power supply as specified by the National Electrical Code. Determine which type of installation will be required; all applications will either use the Normally Open (N.O.) or Normally Closed (N.C.) contacts of the relays provided. The N.O. contacts are closed during normal operation and open in the event of an alarm. The N.C. contacts are open during normal operation and closed in the event of an alarm. Electrical wiring on the averaging sensor should be kept as short as possible as the lead-wire length connected to the averaging sensor's output (red wires) will introduce an offset in the sensor readings. For instance, using 50 ft of 18 AWG wire for each lead of the RTD (100 ft total) will introduce an additional resistance of 0.65 Ohms, the equivalent of 0.3°F. A diagram of the electrical connections can be seen below in figure 5. A sample wiring diagram can be seen in figure 6.

In order to avoid interference due to large amounts of current flowing through the power relay, it is recommended that any lines running through the power relay use a separate conduit hole from the other lines connected to the board, such as the temperature sensor connections and main power.

All cables are to be fed through 3/8" field supplied metal conduit and attached to the appropriate conduit hole of the enclosure using integral fittings.

Note that the barrier is not to be removed during installation and should always be fully in place when the device is in operation.

Electrical Connection Diagram

SIGNAL RELAY

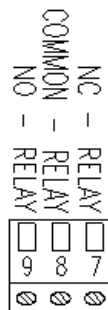

POWER RELAY

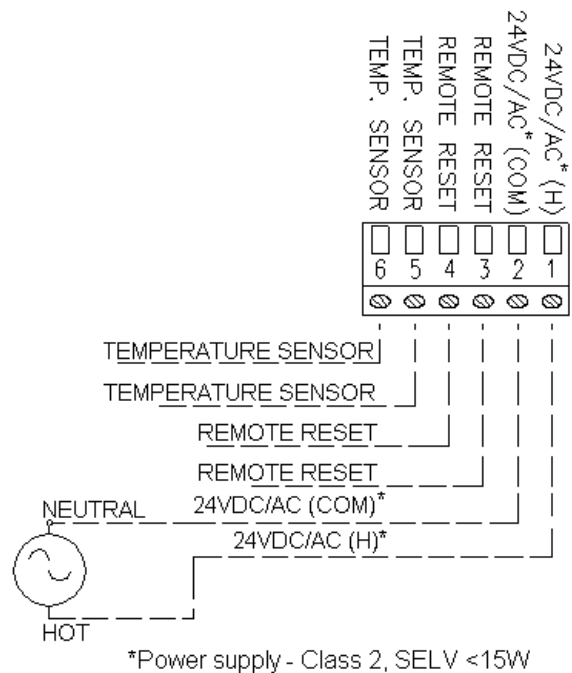
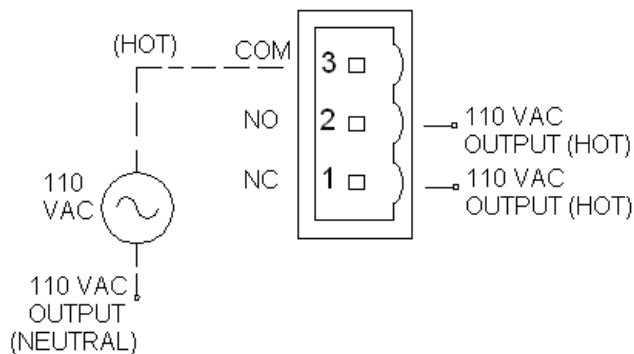

Figure 5 – Diagram of Electrical Connections

Sample Wiring Diagram

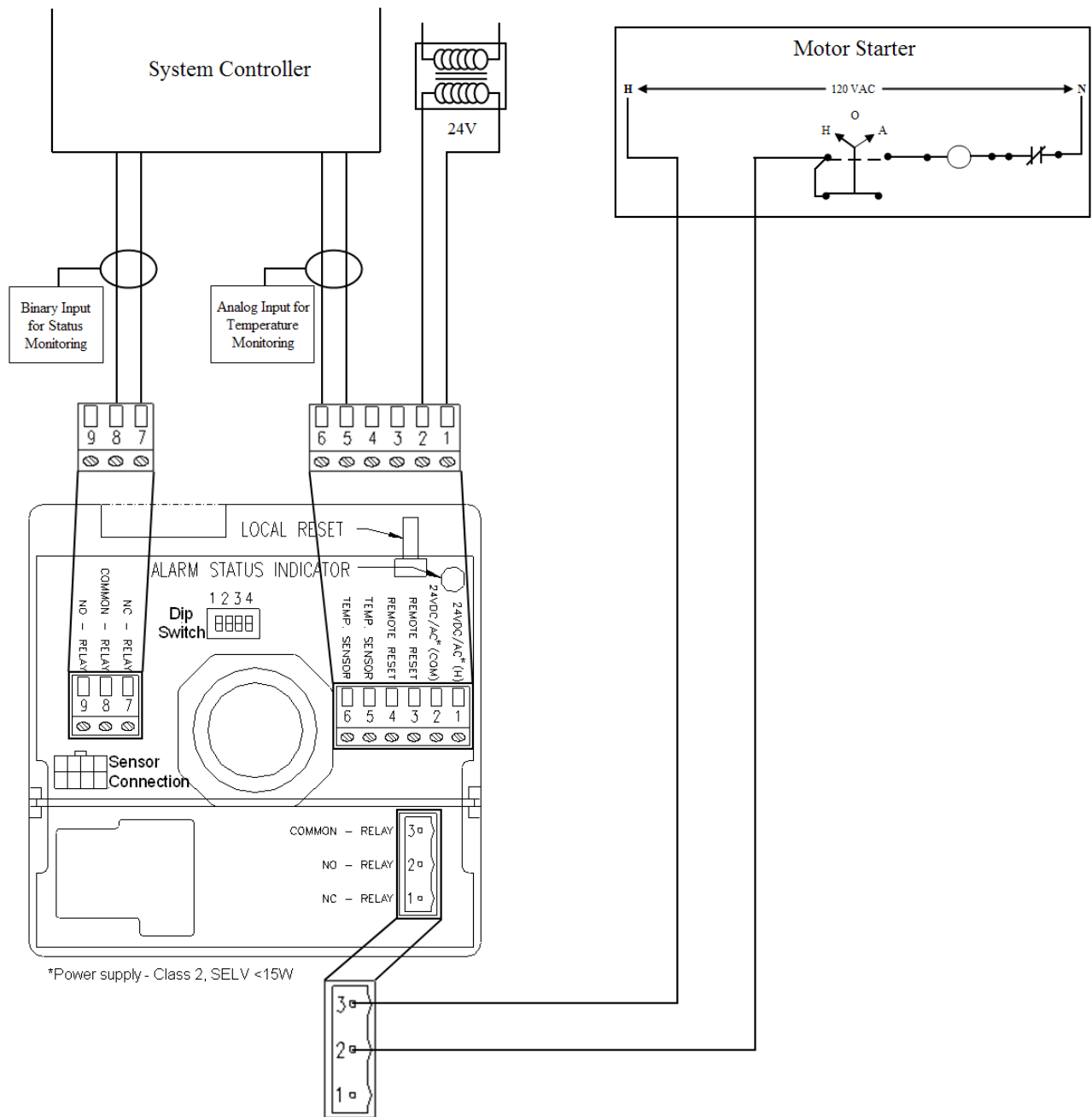

Figure 6 – Sample Wiring Diagram

Series/Parallel Sensor Connections

When it is desired to use only one analog temperature input with multiple devices, the sensors must be connected in a series-parallel combination. The number of sensors in series must match the number of groups in series. Arrangements of 4, 9, or 16 sensors can work this way. Examples can be seen below in figure 7.

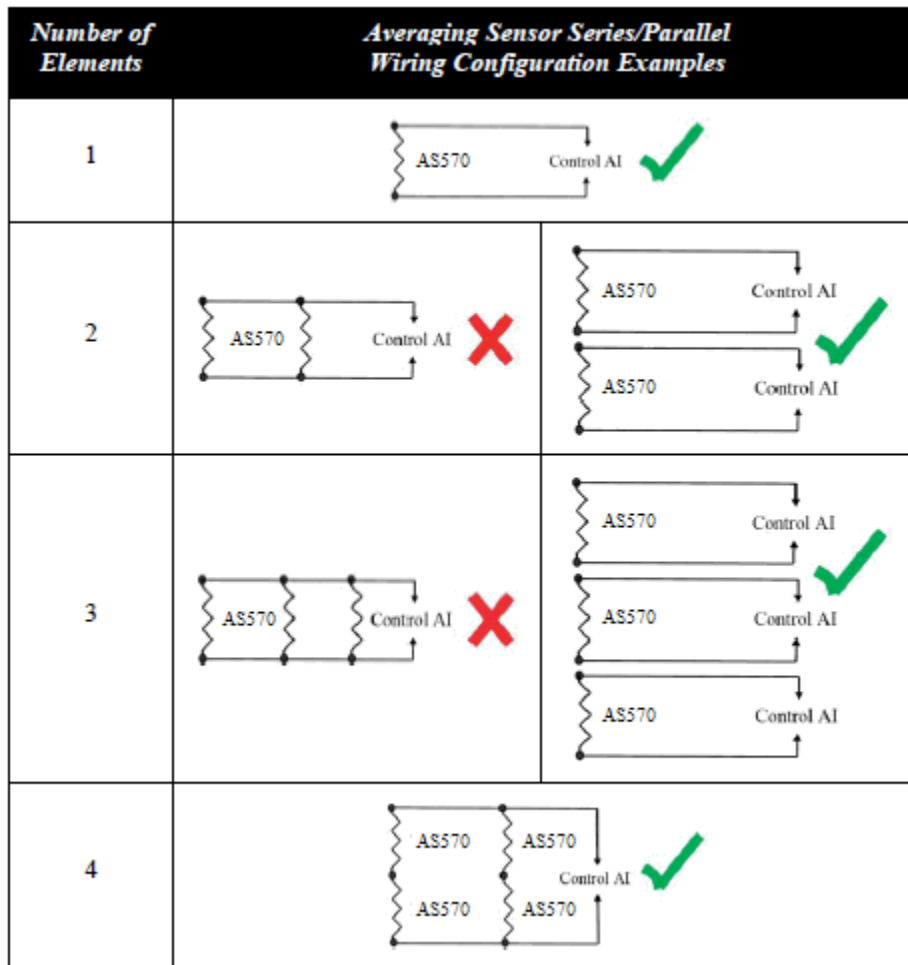

Figure 7 – Series-Parallel Wiring Configuration Examples

Remote Reset Connection

If the application requires remote reset of a latching system, an external push-button switch can be integrated into the system as shown in figure 8. Both wires on the reset switch wire harness should be connected directly to connections 3 and 4 of the six-position terminal block on the board. The switch should be a momentary, normally-open push-button switch. When the switch is depressed to complete the circuit, the reset effect is the same as the local reset switch. This part is not supplied.

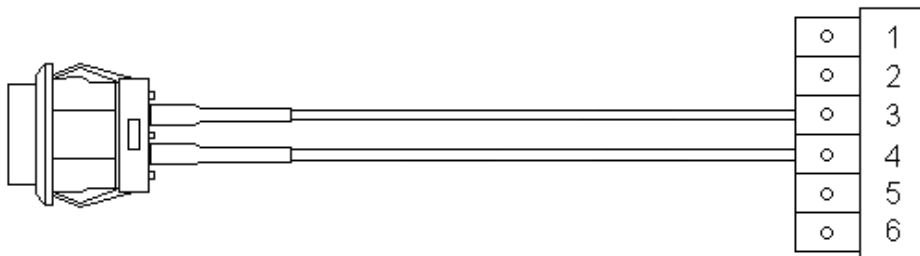
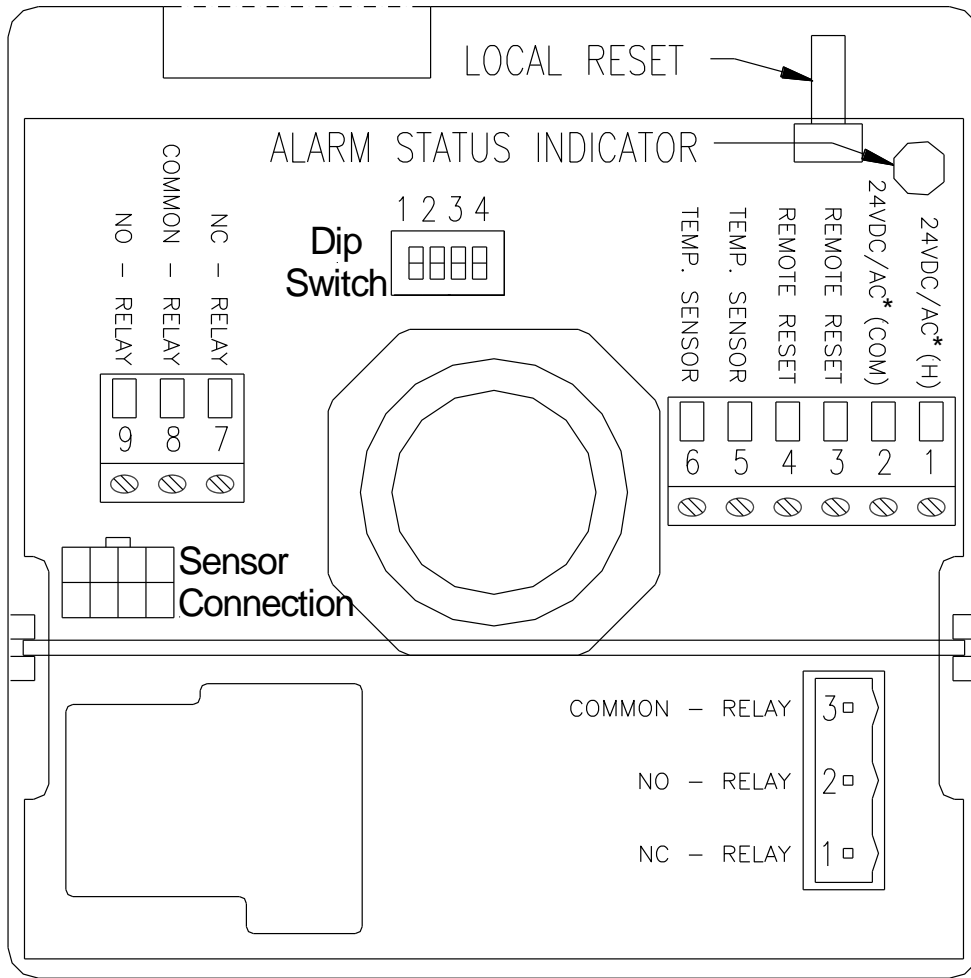

Figure 8 – Remote Reset Using an External Push-Button Switch (NOT SUPPLIED)

Board Layout and Connections



*Power supply - Class 2, SELV <15V

Figure 9 – Internal Board Layout and Connections Diagram

Dimensions: Standard Enclosure Box

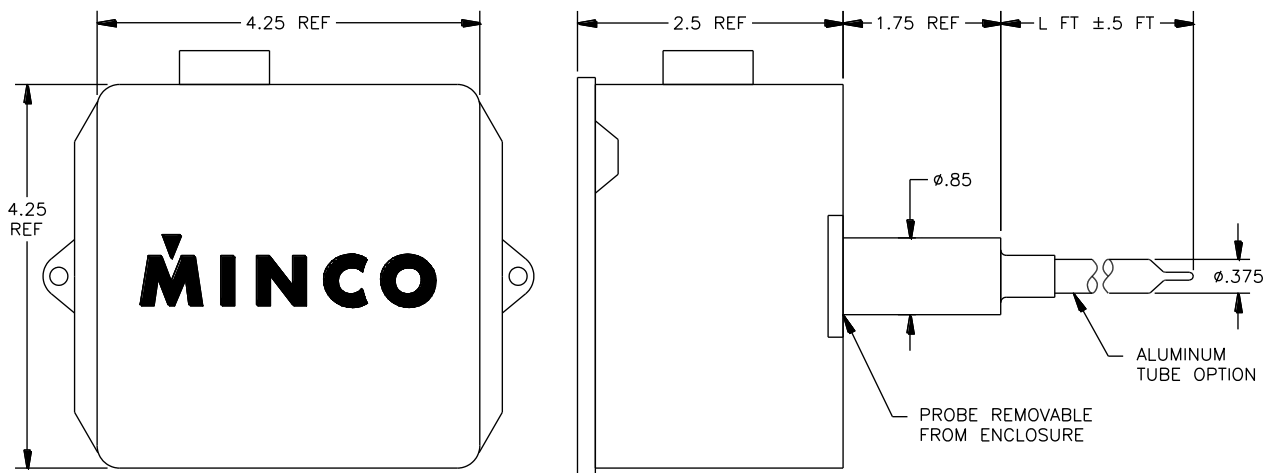

Figure 10 – Dimensions of Standard Enclosure Box

How to Order: AS570 Chill Out

AS570PF8A ← EXAMPLE OF MODEL NUMBER

AS570	SPECIFICATIONS DRAWING NUMBER.
PF	SENSING ELEMENT: PF = 1000 Ω AT 0°C, PLATINUM RTD; TK = 10,000 Ω AT 25°C, NTC THERMISTOR.
8	TUBING LENGTH IN FEET: 8 = 8 FEET; 17 = 17 FEET; 25 = 25 FEET; 50 = 50 FEET.
A	TUBING TYPE: A = BENDABLE ALUMINUM TUBING; B = PVC-COATED FLEXIBLE GALVANIZED STEEL ARMOR.

Warranty

Items returned within three year from the date of sale, transportation prepaid, which Minco Products, Inc. (the "seller") reasonably determines to be faulty by reason of defective materials or faulty workmanship will be replaced or repaired at the seller's discretion, free of charge.

This remedy is to be the sole and exclusive remedy available to the buyer in the event of a breach by the seller. Items that show evidence of mishandling or misapplication may be returned by the seller at the customer's expense.

Furthermore, the seller is not to be held responsible for consequential damages caused by this product except as required under Minnesota Statutes, Section 336.1-719 (3).

This warranty is in lieu of any other expressed warranty or implied warranty of merchantability or fitness for a particular purpose, and of any other obligations or liability of the seller or its employees or agent.

US Patent: 6844805

Minco (Main Office)
7300 Commerce Lane
Minneapolis, MN
55432
USA
Tel: 1.763.571.3121
Fax: 1.763.571.0927

**Customer Service/
Order Desk:**
Tel: 1.763.571.3123
Fax: 1.763.571.0942
custserv@minco.com
www.minco.com

Minco S.A.
Usine et Service
Commercial, Z.I.
09310 Aston, France
Tel: (33) 5 61 03 24 01
Fax: (33) 5 61 03 24 09

Stock # 360-00117(B) 103395

A critical component of your success®
www.minco.com