

Instructions: FG212474 Flameproof and Increased Safety Union Assembly

Ex II 2 G Ex db eb IIC Gb IP65

IECEX Ex db eb IIC Gb IP65

SPI 00-0492 Rev C (Document 2125586)

1. Description

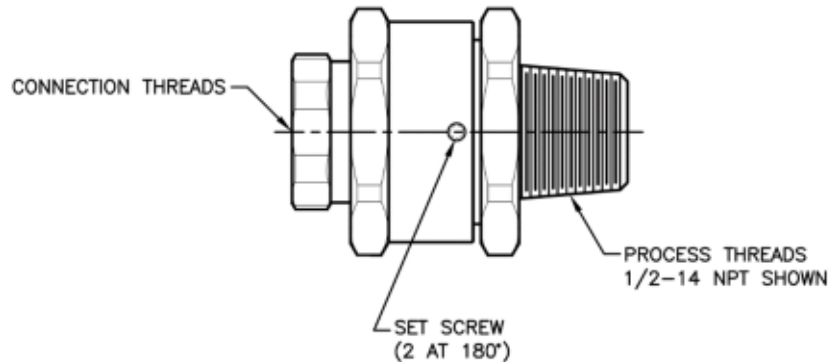

Minco's union assembly has male 'process thread' sizes of 1/2" NPT, 3/4" NPT, 7/8" UNF, and M20; and female 'connection thread' sizes of 1/2" NPT, 3/4" NPT and M20. The union assembly is intended for inline connection into a flameproof enclosure or fitting having male or female threads.

- The fittings may be ordered in stainless steel in grades of type 303 or type 316.
- Once assembled in the desired position, the threaded collar is locked in position by one or two locking set screws, which are positioned 180° radially from each other.
- Unions are ingress protection rated to IP65.

2. Attestation of Conformity

This Attestation of Conformity is issued under the sole responsibility of the manufacturer.

Union Assembly Type: Series FG212474.

The product defined above is in conformity with the following relevant legislation:

ATEX Directive 2014/34/EU

EN 60079-0:2012* Explosive atmospheres - Part 0: Equipment - General requirements

EN 60079-1:2007* Explosive atmospheres - Part 1: Equipment protection by flameproof enclosures "d"

EN 60079-7:2007* Explosive atmospheres - Part 7: Equipment protection by increased safety "e"

IEC 60079-0:2011-06* Explosive atmospheres - Part 0: Equipment - General requirements

IEC 60079-1:2007-04* Explosive atmospheres - Part 1: Equipment protection by flameproof enclosures "d"

IEC 60079-7:2006-07* Explosive atmospheres - Part 7: Equipment protection by increased safety "e"

**NOTE: The harmonized standards EN IEC 60079-0:2018, EN 60079-1:2014, and EN IEC 60079-7:2015+A1:2018 have been compared to the standards used for certification purposes and no changes in the "state of the art" apply to the product. The standards IEC 60079-0:2017/COR1:2020, IEC 60079-1:2014, and IEC 60079-7:2015+AMD1:2017 have been compared to the standards used for certification purposes and no changes in the "state of the art" apply to the product.*

Certificate Baseefa14ATEX0192U

Certificate IECEX BAS 13.0085U

SGS Fimko Oy (0598)

Särkiniementie 3

P.O. Box 30 FI-00211

Helsinki, Finland

Rob Bohland 06 Mar 2023

Rob Bohland, Ex Authorized Person

Minco Products, Inc

7300 Commerce Lane

Minneapolis, MN 55432 USA

3. Installation Instructions

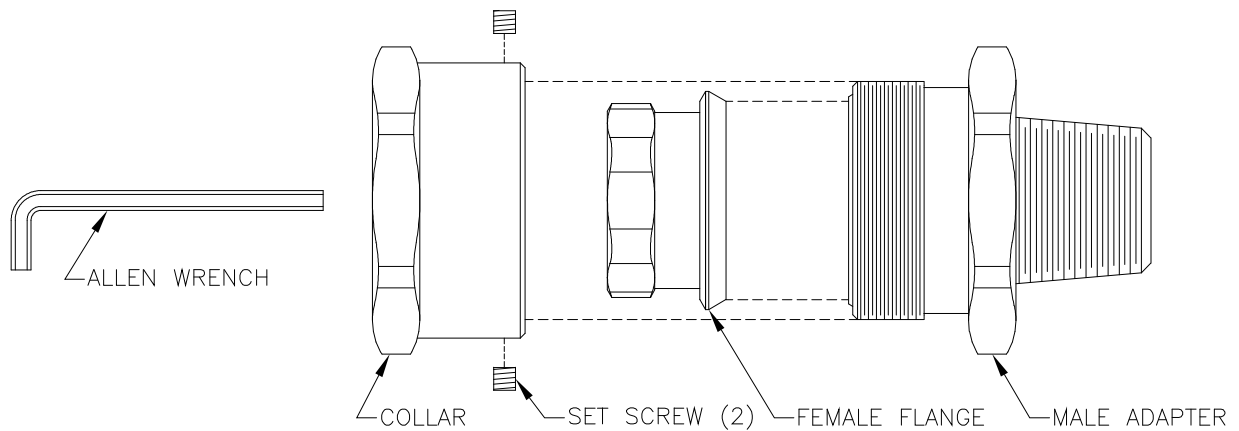

The union assembly package includes a male adapter, female flange, threaded collar, 2 set screws, and an allen wrench.

1. Thread the process thread of the male adapter into the enclosure or machine threads.
2. Pass the conductors through the enclosure or machine and union assembly.
3. Place the female flange onto the end of the male adapter, aligning the serrated flamepaths, and thread the collar onto the male adapter by hand. The male adapter and the female flange will be held together by the threaded collar. Lightly wrench tighten the threaded collar.
4. Using the allen wrench, tighten at least one of the set screws to lock the threaded collar in position.
5. Add an enclosure or other conduit fitting by threading into the threads of the female flange.

4. Schedule of Limitations

- The union, when used in flameproof applications, must not be closed with a flameproof stopping plug.
- The 'male adapter' has the option of two parallel process thread options (metric and UNF) which have a 3.5 mm (maximum) undercut at the base of the entry thread, and therefore must only be fitted into a flameproof enclosure with entries having a minimum of 14mm full thread form measured from the external surface.
- As an alternative to the previous limitation, the flameproof gland must be fitted with a non-detachable, non-compressible washer having a minimum thickness of 2mm between the head of the gland and enclosure.
- When process or connection threads are of parallel thread form, additional measure must be taken to seal the threads in order to maintain the union's IP65 rating.