

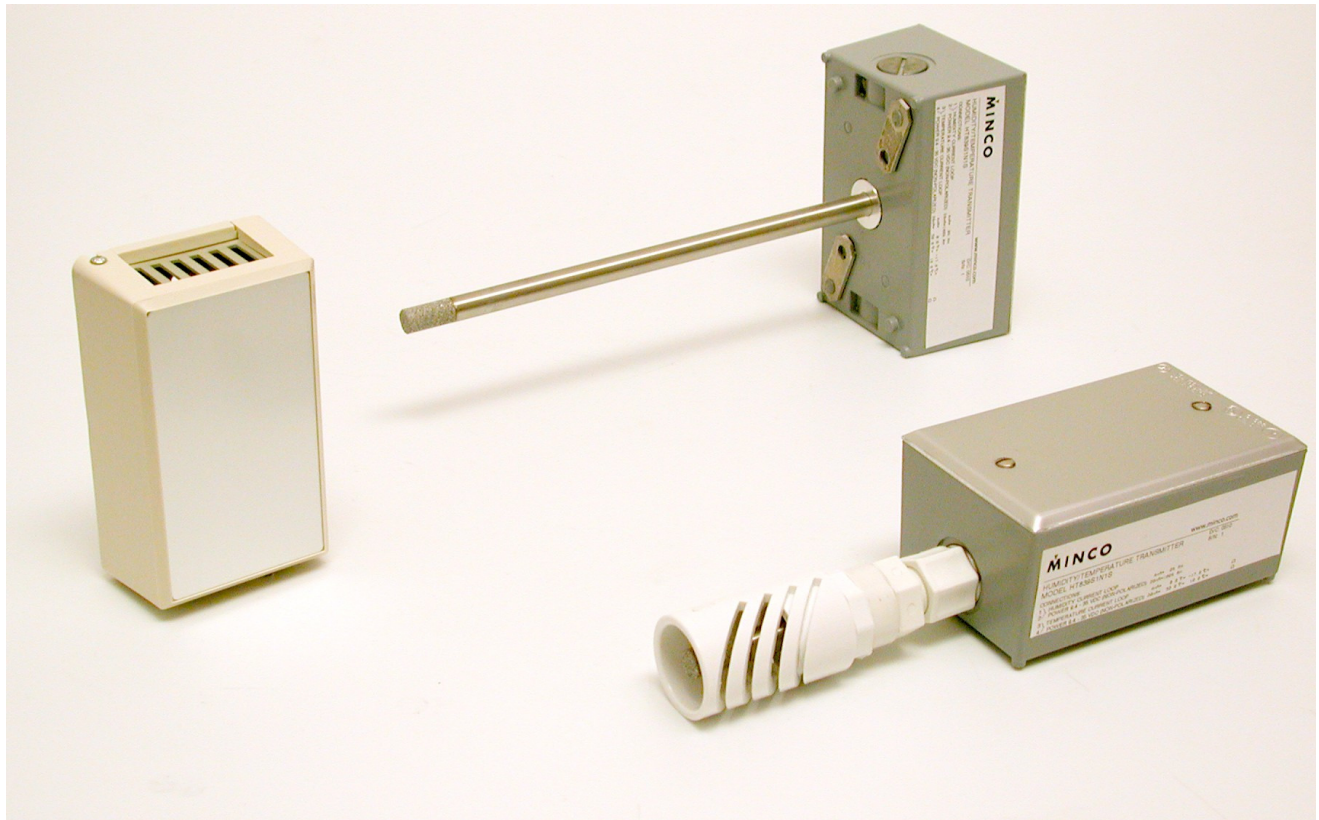

HT2 Humidity Transmitter HT2 Humidity and Temperature Transmitter Installation and Operating Instructions



Description

Model HT2 is a 2-wire temperature compensated humidity transmitter with an optional temperature transmitter output. The transmitter utilizes a Honeywell HIH series monolithic IC humidity sensor which provides excellent stability and chemical resistivity. The transmitter converts the humidity sensor's signal into a 4 to 20 mA DC current, which changes proportionally from 4 mA at 0% RH to 20 mA at 100% RH. The optional temperature loop produces a second 4 to 20 mA DC output where the current changes from 4 mA at the lowest temperature of the range, to 20 mA at the top of the temperature range. The leads that supply power also carry the current signal. The HT2 is available in duct mount, wall mount, outside air (OSA), and space mount configurations.

Specifications

Output(s):	Humidity: 4 to 20 mA DC = 0% to 100% RH. Temperature: 4 to 20 mA DC over specified range (optional)
Sensing Element:	Humidity: Capacitive monolithic IC. Temperature: 1000 ohm platinum; 2 lead RTD.
Ambient Temperature:	
Operating:	Room: -10 to 150°F (-23 to 65°C), non-condensing. Duct/Wall/OSA: -10 to 185°F (-23 to 85°C), non-condensing.
Storage:	Room: -58 to 150°F (-50 to 65°C), non-condensing. Duct/Wall/OSA: -58 to 185°F (-50 to 85°C), non-condensing.
Supply voltage:	9.4 to 35 VDC, non-polarized.
Voltage effect:	.001% of span/volt from 9.4 to 35 VDC.
Loop resistance:	The maximum allowable resistance of the signal-carrying loop, including extension wires and load resistors, is given by this formula: $R_{loopmax} = (V_{supply} - 9.4) / 0.02 \text{ AMPS}$. For example, if supply voltage is 24 VDC, the loop resistance must be less than 730Ω.
Accuracy:	Includes temperature, linearity, hysteresis, repeatability, and voltage effects.
Humidity:	±2% from 0% to 90% RH @ 25°C. ±3% from 0% to 90% RH from 15 to 50°C. ±5% from 0% to 90% RH from 0 to 82°C.
Temperature:	±0.5°F (0.27°C) @ 25°C or +/- 0.8% of span, whichever is greater.
Adjustments:	None.
Time Constant:	50 seconds in slow moving air.
Connections:	Screw terminals (22-14 AWG wire).
Weight:	Room: 0.19 lb (.084 kg). Duct/Wall/OSA: 1.20 lb (0.55 kg).
Minimum output current:	3.5 mA.
Maximum output current:	23 mA.

Installation Do's and Don'ts

Do:

- Check the label and verify the model number of the unit.
- Confirm the required power and signal wires are available at installation site.
- Avoid electrical interference with other signals by using twisted pair wiring. Do not run signal leads near or parallel to line voltage or other power leads.
- Mount the unit on an interior wall located away from air drafts coming from forced air heating/cooling vents, within the wall and/or the wiring conduit.

Don't:

- Do not touch or manipulate the sensors.
- Do not expose the sensor to direct light during installation. This causes a false reading. Should this occur, shade the sensor. It will self-adjust and yield an accurate reading in less than two minutes.
- Do not expose the sensor or transmitter to static electricity. This device incorporates CMOS components which are vulnerable to damage via static charges.

Mounting

Installation of the HT2 consists of mounting the transmitter and connecting it to power.

Space Mounting: Model HT2S...

1. Separate the plastic base plate from the cover.
2. Mount the base plate using two countersink screws to the wall. The long edge to the vertical, observing the directional arrow marked on the base plate.
3. Connect power wires to the transmitter by 2 screw terminals located near the edge of the circuit board (figures 1 and 3). Power supply must not exceed 35 VDC.
4. Re-install cover to base plate.

Duct/Wall/OSA Mounting: Models HT2D... HT2O... HT2W...

1. For the duct mount model HT2D only, drill ½" hole into sheet metal of duct. (Probe is 3/8" in diameter.)
2. Using the fold-out tabs on bottom of housing, mount housing to sheet metal.
3. Remove transmitter cover and connect power wires to the transmitter by 2 screw terminals located near the edge of the circuit board (figures 2 and 4). Power supply must not exceed 35 VDC.
4. Re-install cover.

HT2 (Humidity Only) Wiring Diagrams

Space Mount

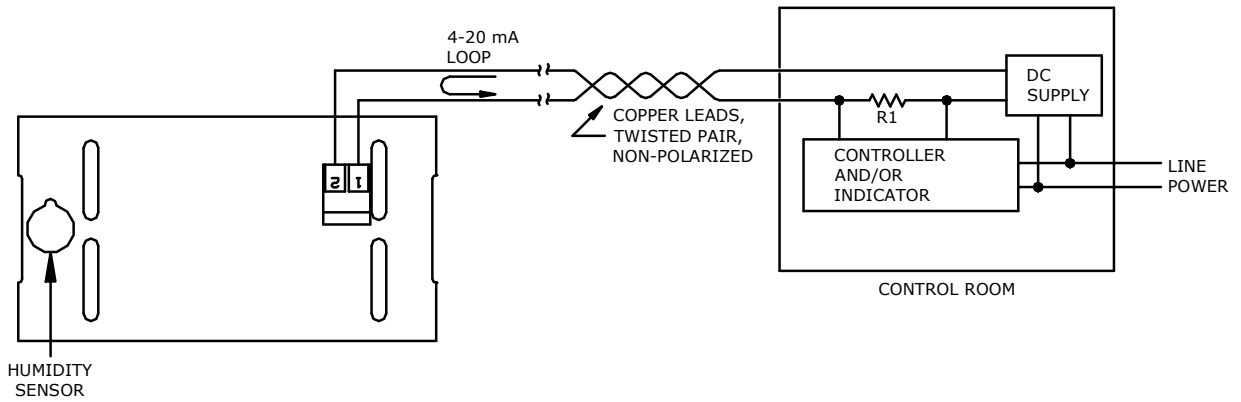

Figure 1

Duct/Wall/OSA Mount

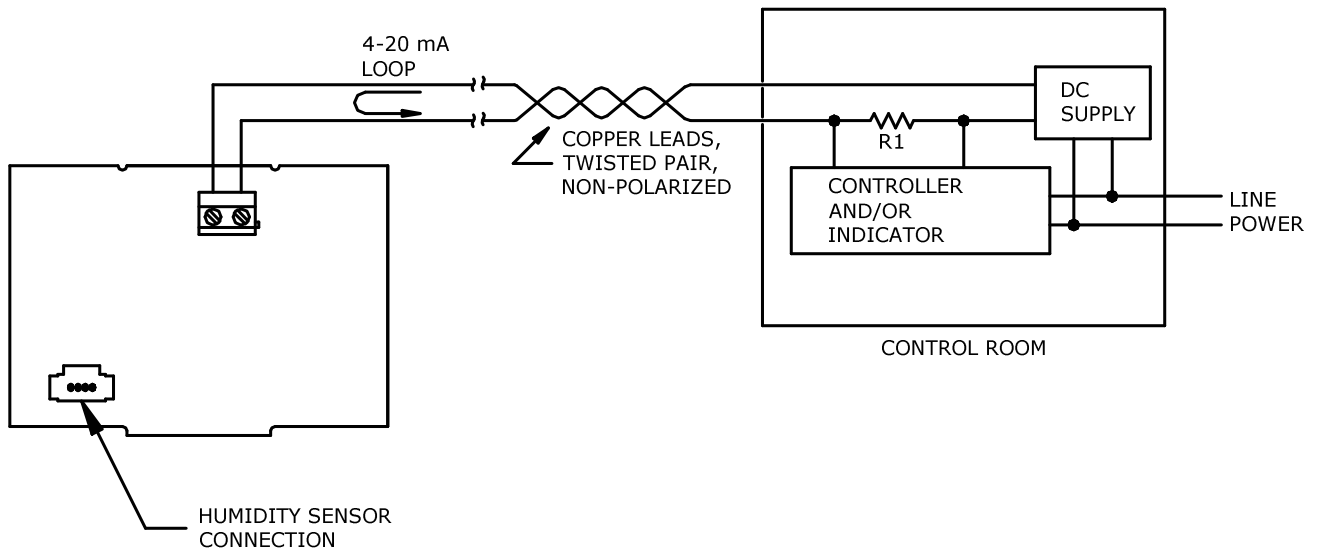

Figure 2

HT2 (Humidity and Temperature) Wiring Diagrams

Space Mount

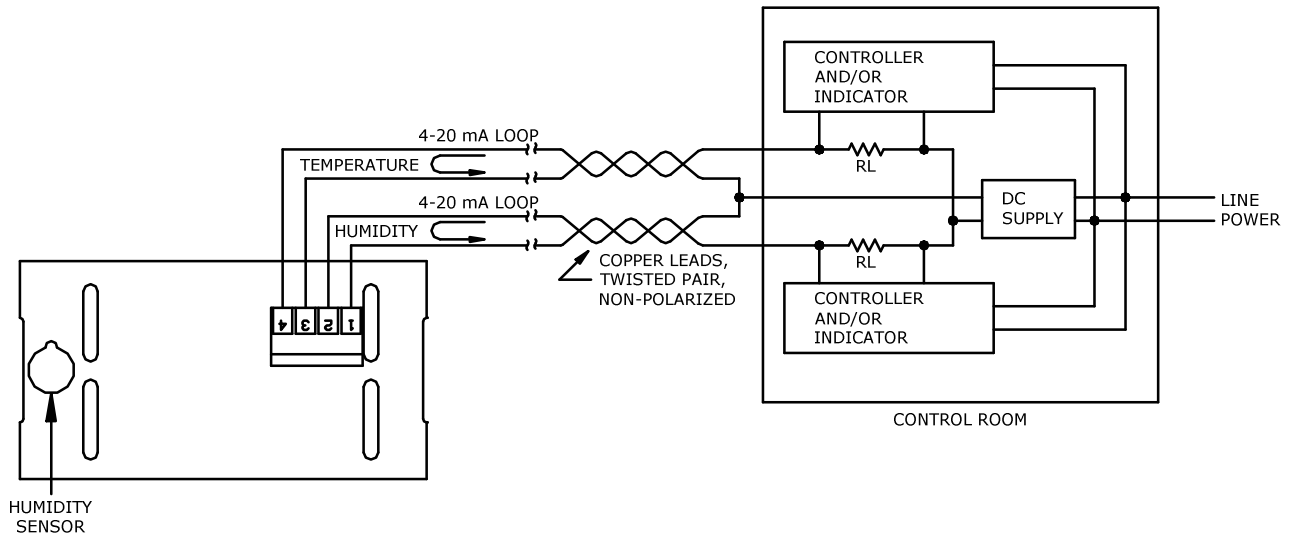

Figure 3

Duct/Wall/OSA Mount

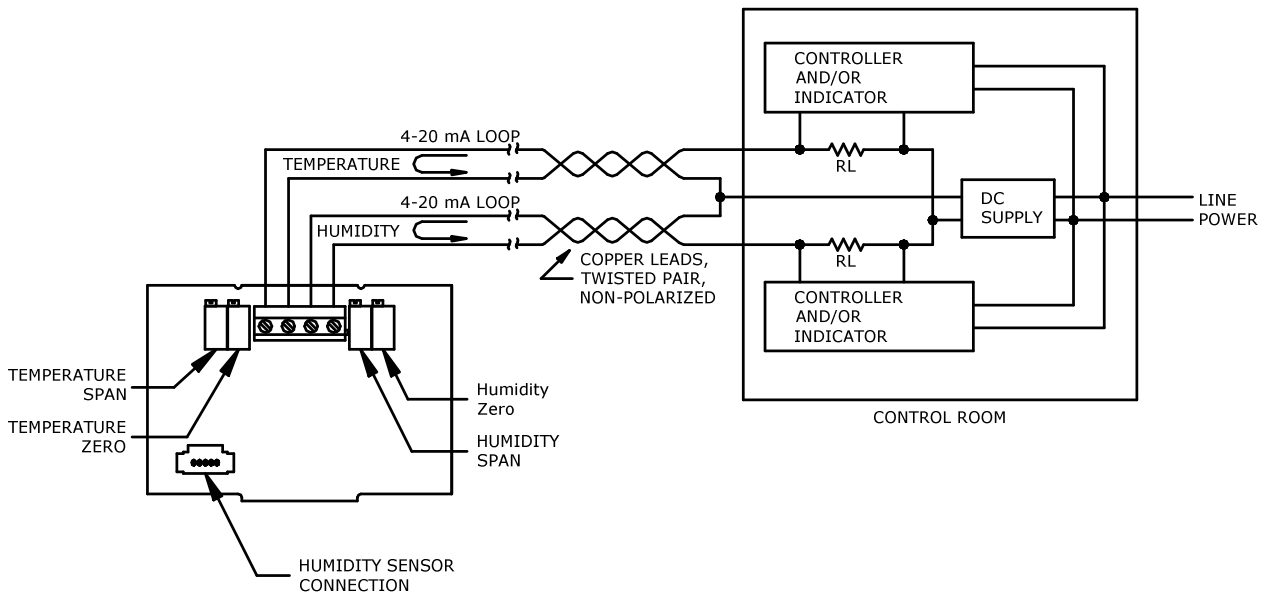

Figure 4

Note: When using a transmitter with both humidity and temperature, both loops must be powered to receive a signal from the transmitter.

Power Supply

DC power supply requirements are determined by the HT2's minimum voltage requirement and voltage drop across the load resistor and installation lead wires.

Example: The transmitter requires 9.4 Volts minimum. A typical 250 ohm load resistor drops 5.0 Volts @ 20 mA. Allowing a margin of 0.5 Volts for the supply permits 25 ohms of lead wire resistance for remote installation. Totaling these, we get a minimum power supply requirement of 14.9 VDC.

Using a 24 VDC power supply will take care of nearly all installations, but the HT2 will operate at voltages up to 35 VDC.

Humidity Transmitter Calibration

Factory calibrated. No field calibration required.

Warranty

Items returned within one year from the date of sale, transportation prepaid, which Minco Products, Inc. (the "seller") reasonably determines to be faulty by reason of defective materials or faulty workmanship will be replaced or repaired at the seller's discretion, free of charge.

This remedy is to be the sole and exclusive remedy available to the buyer in the event of a breach by the seller. Items that show evidence of mishandling or misapplication may be returned by the seller at the customer's expense.

Furthermore, the seller is not to be held responsible for consequential damages caused by this product except as required under Minnesota Statutes, Section 336.1-719 (3).

This warranty is in lieu of any other expressed warranty or implied warranty of merchantability or fitness for a particular purpose, and of any other obligations or liability of the seller or its employees or agent.

How to Order HT2

HT2	Model Number: HT2 – Humidity Transmitter (Temperature Transmitter Optional)
D	Enclosure: D = Duct mount, 8" probe length O = Outside Air/Wall mount, 4" probe length with shield, weather resistant enclosure S = Space mount W = Wall mount, 4" probe length, weather resistant enclosure
1	Output: 4 to 20 mA DC
S	Temperature Transmitter range: NT = No Temperature Transmitter EN = -20°F to 140°F S = 0°F to 100°F A = 20°F to 120°F BI = 30°F to 130°F KK = 30°F to 180°F N = 32°F to 122°F H = 40°F to 90°F
HT2D1S ← Sample part number	

Dimensions

Space Mount

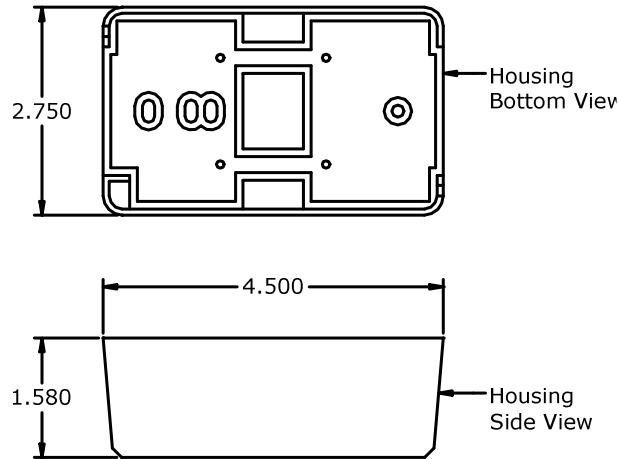

Duct, Wall, and Outside Air Mount

Duct

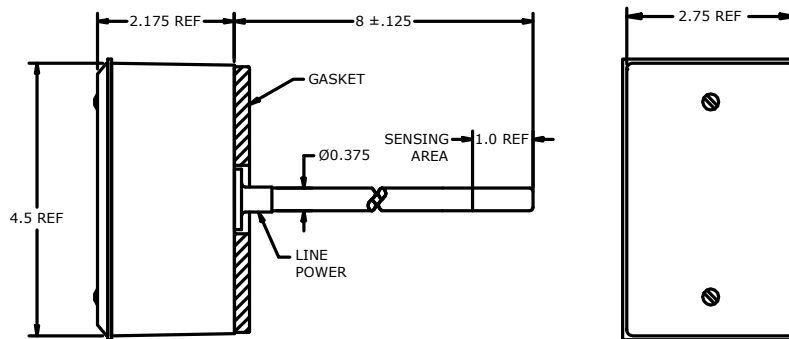

OSA

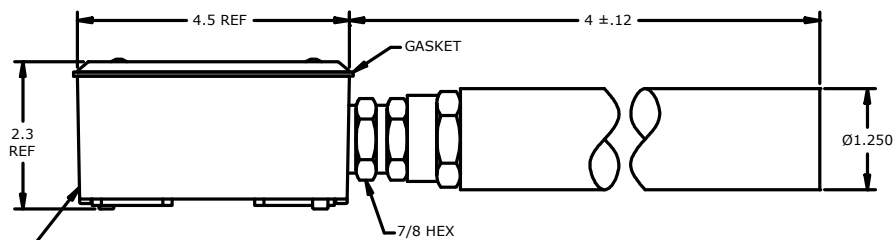

Wall

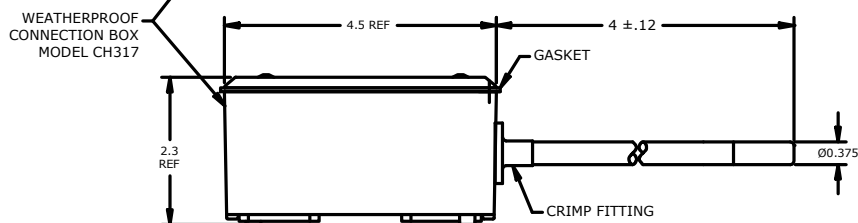

Worldwide Headquarters
 7300 Commerce Lane
 Minneapolis, MN 55432 USA
 Tel: 1.763.571.3121
 Fax: 1.763.571.0927
 sales@minco.com
 www.minco.com

European Headquarters
 Usine et Service
 Commercial, Z.I.
 09310 Aston, France
 Tel: (33) 5 61 03 24 01
 Fax: (33) 5 61 03 24 09

Asia Pacific Headquarters
 20 Science Park Road
 #02-31 Teletech Park
 Singapore Science Park II
 Singapore 117674
 Tel: (65) 6511 3388
 Fax: (65) 6511 3399

ISO 9001:2000 / AS9100B

© Minco 2009
 F:\MOD\HT2\LIT\
 1028MN.DOC
 Stock # 360-00103(E)
 082409



Flex Circuits
 Thermofoil™ Heaters
 Sensors
 Instruments