

Instructions: Intrinsic Safety and Increased Safety Miniature Temperature Detectors

Ⓔ II 1 G Ex ia IIC Ga

IECEX Ex ia IIC Ga

CSAc-us Class I, Zone 0, Ex/AEx ia IIC Ga

Ⓔ II 2 G Ex eb IIC Gb

IECEX Ex eb IIC Gb

CSAc-us Class I, Zone 1, Ex/AEx eb IIC Gb

Ⓔ II 3 G Ex ec ic IIC Gc

IECEX Ex ec ic IIC Gc

CSAc-us Class I, Zone 2, Ex/AEx ec IIC Gc, resp. ic IIC Gc

Intrinsic Safety, Class I, Division 1 & 2, Groups ABCD

Class I, Division 2, Groups ABCD

SPI 00-1069 Rev. D (Document 2580343)

1. Description

These temperature sensors are designed to be installed in various locations.

- Operating temperature range is -60°C to +200°C (elastomer filled cable limited to +125°C; polyimide insulated leadwires, and FEP jacket on cables, limited to 180°C).
- S_____ resistance temperature detector (RTD) models are available for 2-, 3- or 4-wire measurement circuits and with single or dual RTD elements.
- TC_____ thermocouple models are available with single or dual thermocouple elements.
- Accessories:
 - Feedthroughs can be used in assemblies with temperature sensors S_____ models and TC_____ models.
 - Operating temperature range is -60°C to +85°C (available to +135°C on special order).
 - Pressure tested to 25 psi (1.7 bar).
 - Various springs and rings are available to fit flanged case sensors (Minco case style B).
 - Case tip babbitt layer available on Minco case styles A and B.

2. Attestation of Conformity

This Attestation of Conformity is issued under the sole responsibility of the manufacturer.

Miniature Temperature Sensors Type B216681.

The product defined above is in conformity with the following relevant legislation:

ATEX Directive 2014/34/EU

EN 60079-0:2012+A11:2013 Explosive atmospheres - Part 0: Equipment - General requirements

EN 60079-7:2015 Explosive atmospheres - Part 7: Equipment protection by increased safety "e"

EN 60079-11:2012 Explosive atmospheres - Part 11: Equipment protection by intrinsic safety "i"

IEC 60079-0:2017-12 Explosive atmospheres - Part 0: Equipment - General requirements

IEC 60079-7:2017-08 Explosive atmospheres - Part 7: Equipment protection by increased safety "e"

IEC 60079-11:2011-06 Explosive atmospheres - Part 11: Equipment protection by intrinsic safety "i"

CAN/CSA C22.2 No. 60079-0:15 Explosive atmospheres - Part 0: Equipment - General requirements

CAN/CSA C22.2 No. 60079-7:16 Explosive atmospheres - Part 7: Equipment protection by increased safety "e"

CAN/CSA C22.2 No. 60079-11:14 Explosive atmospheres - Part 11: Equipment protection by intrinsic safety "i"

CAN/CSA C22.2 No. 61010-1-12 Safety requirements for electrical equipment for measurement, control, and laboratory use
- Part 1: General requirements

ANSI/UL 60079-0-2013 Explosive atmospheres - Part 0: Equipment - General requirements

ANSI/UL 60079-7-2017 Explosive atmospheres - Part 7: Equipment protection by increased safety "e"

ANSI/UL 60079-11-2014 Explosive atmospheres - Part 11: Equipment protection by intrinsic safety "i"

ANSI/UL 61010-1:2012 Safety requirements for electrical equipment for measurement, control, and laboratory use
- Part 1: General requirements

National Electrical Code NFPA 70 Article 500

continued on next page

Canadian Electrical Code CSA C22.1 Annex J

Certificate SIRA 18ATEX2074U
Certificate SIRA 18ATEX2309U
Certificate IECEX SIR 18.0027U
Certificate CSA 19.70217566
CSA Group Netherlands B.V. (2813)
Utrechtseweg 310, Building B42
6812AR, Netherlands

 17 July 2020
Rob Bohland, Ex Authorized Person
Minco Products, Inc
7300 Commerce Lane
Minneapolis, MN 55432 USA

3. Installation Instructions

A separate installation instruction is included with each shipment of miniature temperature sensors. If lost, a copy can be downloaded from the Minco website (www.minco.com). The appropriate Engineering Instruction(s) for each model is as follows:

- **Case Style A:**
EI 164 Temperature Sensor in Journal Bearing Using the Babbitt Method for Case Style A or EI 167 Temperature Sensor in Thrust Bearing, Case Style A.
- **Case Style B:**
EI 180 Temperature Detector in Thrust Bearing, Case Style B, Babbitt Method or EI 181 Temperature Detector in Thrust Bearing, Case Style B, Spring and Ring Method.
- **Case Styles C and D:**
EI 184 Temperature Detector in Bearing Shoe Case, Case Style C and D, Potting Method.
- Feedthrough Accessory Installation: When ordered with a case style B bearing sensors, spring and ring are automatically included.
- See page 2 of model specification drawing for accessory assembly features.
- Installation of Temperature Detectors shall be carried out only by persons whose training has included instruction on the various types of protection and installation practices, relevant rules and regulations and on the general principles of area classification. The competency of the person shall be relevant to the type of work to be undertaken.

4. Special Conditions for Safe Use

The equipment is Intrinsic Safety and Increased Safety rated, and can be used in potentially explosive atmospheres. Because of the 3 protection modes available, the user must check the appropriate box on the marking label (See §8. Marking Examples.)

All Installations:

The electrical parameters of the associated equipment must not exceed any of the following values:
 $U_o \leq 30 \text{ V}$, $I_o \leq 46 \text{ mA}$ and $P_o \leq 0.4 \text{ W}$.

For North America, power supplied to this equipment shall be from a source considered "Class 2", per the Canadian Electrical Code Part I, C22.1, Section 16-200, and the National Electrical Code, NFPA 70, Article 725.121. Connect using National Electrical Code, NFPA 70, Articles 504 and 505, and Canadian Electrical Code Part I, C22.1, Section 18.

After installation, the user shall ensure that the ambient temperature is respected for the apparatus and connected equipment. It shall be suitable for the measured service temperature with the temperature sensor installed.

Intrinsic Safety Installations only:

The apparatus must be only connected to certified associated intrinsic safety equipment and this combination must be compatible as regards to intrinsic safety rules.

The electrical parameters of the associated intrinsic safety equipment must not exceed any of the following values:
 U_o (or V_{oc}) $\leq 30 \text{ V}$ and $P_o \leq 0.4 \text{ W}$.

The connection of the cable must be effected in an enclosure with a minimum protection degree IP20 according to clause 6.1 of the standard EN 60079-11.

After integration in the end-use system, the apparatus shall be submitted to a dielectric test of 500VAC, 50/60HZ during 60 Seconds without breakdown at 5 mA RMS, according to Clause 10.3 of CAN/CSA C22.2 No. 60079-11:14, ANSI/UL 60079-11-2014, and IECEX/EN 60079-11(not applicable for grounded junction thermocouples).

Increased Safety Installations only:

This device is OPEN type equipment that must be used within a suitable end-use system enclosure, the interior of which is accessible only through the use of a tool.

Flying leads must be terminated within a suitable enclosure having a screw or spring terminal suitable for use with 24 AWG (0.25 mm²) or smaller conductors which are appropriately rated for the service temperature, maintain the required spacings, (Creepage: 1.8 mm “eb” and 1.3 mm “ec”; Clearance: 1.8 mm “eb” and 0.8 mm “ec”); and secures against accidental disconnection.

This device must be installed in an appropriately certified (e.g. Ex p, Ex d, Ex e, Ex nA or equivalent protection concept) enclosure, which provides a minimum ingress protection of IP54 and protects against mechanical impact.

After integration in the end-use system, the apparatus shall be submitted to a dielectric test of 500VAC, 50/60HZ during 60 Seconds without breakdown at 5 mA RMS, according to Clause 7.1 of CAN/CSA C22.2 No. 60079-7:15, ANSI/UL 60079-7-2017, and IECEx/EN 60079-7 (not applicable for grounded junction thermocouples).

5. Entity Parameters and Electrical Data

The following applies to all protection modes:

	S____ models	TC____ models
Maximum input voltage U_i (or V_{max})	30 V	30 V
Maximum input power P_i (or P_{max})	0.40 W	n/a
Maximum input current I_i (or I_{max})	46 mA	46 mA

For intrinsic safety: Cable: $Ci_{max} = 0.028\eta F/m$ $Li_{max} = 0.0013mH/m$ $Ri_{max} = 0.16 \Omega/m$

6. Temperature Class Tables

For installation, the user shall ensure that the ambient temperature of connective parts is respected. It shall not be impacted by the measured temperature.

The temperature class rating of the equipment is determined according to the ambient temperature (process side) and the dissipated power in the sensor.

Power dissipated in the S____ (RTD) sensor	Maximum Temperature				
	Class T6	Class T5	Class T4	Class T3**	Class T2***
0.1 W	+70°C	85°C	120°C	185°C	200°C
0.2 W	+65°C	80°C	115°C	180°C	200°C
0.4 W	+50°C	65°C	100°C	165°C	200°C

Power dissipated in the TC____ (thermocouple) sensor	Maximum Temperature				
	Class T6	Class T5	Class T4	Class T3**	Class T2***
0.1 W	+70°C	85°C	120°C	185°C	200°C

**Elastomer-filled cables should not be used for T3 temperature class applications. Feedthroughs should not be used on T3 temperature class applications where ambient temperature exceeds +85°C (or +135°C on special orders).

***Elastomer-filled cables and feedthroughs should not be used on T2 temperature class applications.

7. Electrical Connections

S____ models:

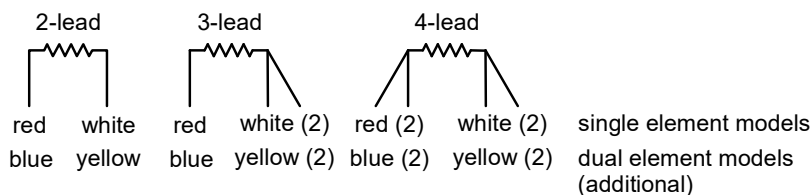

TC____ models:

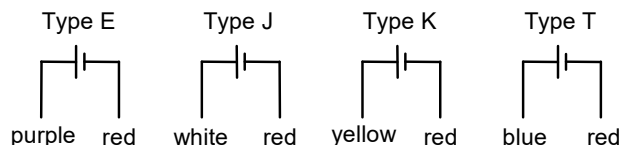

The above color code is Minco's standard colors, but alternatives can be used. Refer to the model specification drawing for the actual color code.

8. Block Diagram

The following applies to intrinsic safety protection mode.

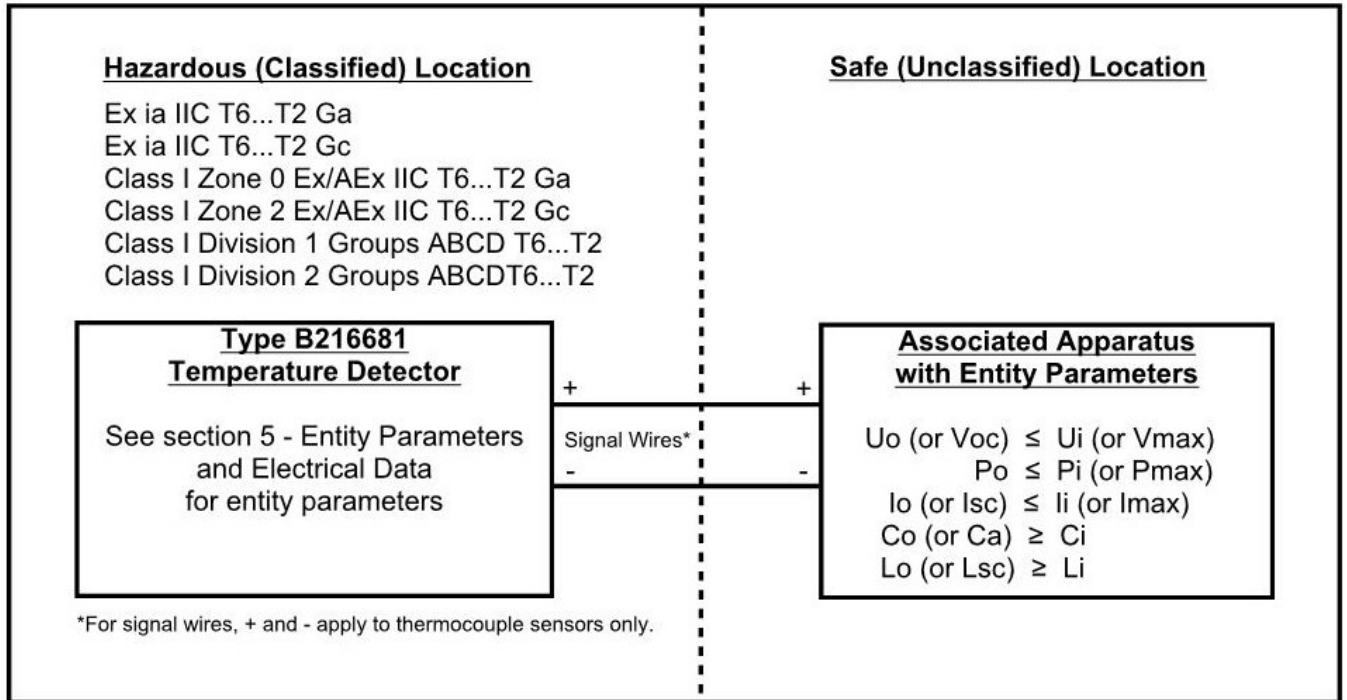

9. Marking Example

Temperature detectors may be manufactured in our facilities in the United States or France. Below is an example of identification of manufacturing facility site.

IMPORTANT: On the marking label, the user must check the box (☐) corresponding to the selected protection mode.

FRONT SIDE	REAR SIDE
<p>MINCO MINNEAPOLIS, MN USA Mfg site: _____ Type: <i>B216681</i> Model: _____ Batch number: <i>123456--*--001</i> <i>Ta: -60C to +200C (elastomer +125C)</i> See installation instructions for complete details.</p> <p>☒ nnnn 19.70217566 $U_i \leq 30V, 0.1W \leq P_i \leq 0.4W, I_i \leq 46mA$</p>	<p><input type="checkbox"/> ☒ II 1G Ex ia IIC Ga <input type="checkbox"/> ☒ II 2G Ex eb IIC Gb <input type="checkbox"/> ☒ II 3G Ex ic IIC Gc <input type="checkbox"/> ☒ II 3G Ex ec IIC Gc</p> <p>SIRA 18ATEX2074U, SIRA 18ATEX2309U IECEX SIR 18.0027U</p> <p>IS CL I Div1 Gp ABCD, CL I Div2 Gp ABCD CL I Zn 0 Ex/AEx ia IIC Ga CL I Zn 1 Ex/AEx eb IIC Gb CL I Zn 2 Ex/AEx ec IIC Gc, resp ic IIC Gc</p>

Specific label markings:

Manufactured In USA:

Mfg site: Minneapolis, MN USA

Notified Body No. nnnn = 0344

Manufactured In France:

Mfg site: Aston-France

Notified Body No. nnnn = 0081