

Temptran™/Explosionproof Connection Head Assembly

Round and rectangular Temptran transmitters are mounted in explosionproof connection heads using the AC101376 as listed in the table below:

Mounting Kit	Fits in Connection Heads
AC101376	CH105, CH107, CH328, CH330, CH343, CH357, CH358, CH405, CH407

Contents:

- terminal board,
- #6-32 × 3/16" screw (2),
- #8 × 1/2" sheet metal screw (1),
- #6-32 × 3/8" screw (2),
- #6-32 kep nut (2),
- #4-40 × 5/16" self threading screw (2).

Mounting round, "hockey puck" Temptran™ in connection head

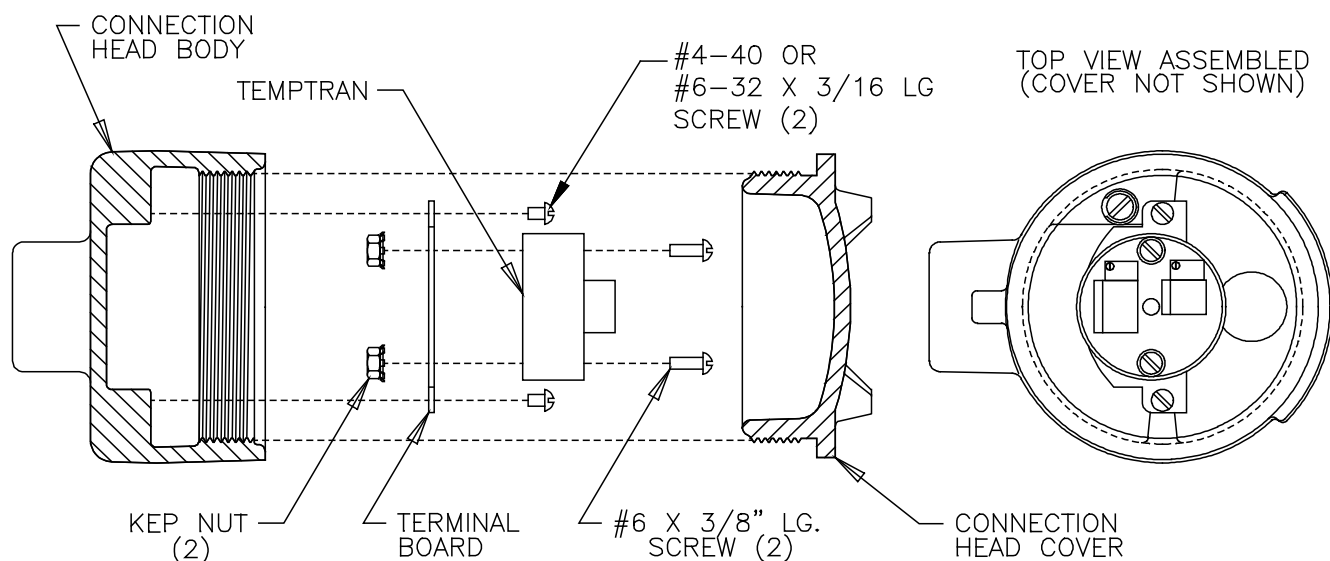

Procedure

The AC101376 mounting kit, round Temptran transmitters and connection head are assembled following the instructions below.

Step	Action
1	Unscrew cover from connection head body.
2	Mount round, hockey puck style Temptran to terminal board using #6 × 3/8" long screws and kep nuts.
3	Mount Temptran/terminal board assembly to connection head body using #6 × 3/16" long screws.
4	Make necessary wiring connections per Temptran wiring instructions.
5	Screw cover back onto connection head body and close tightly.

Temptran™/Explosionproof Connection Head Assembly, Continued

Mounting miniature, rectangular Temptran™ in connection head

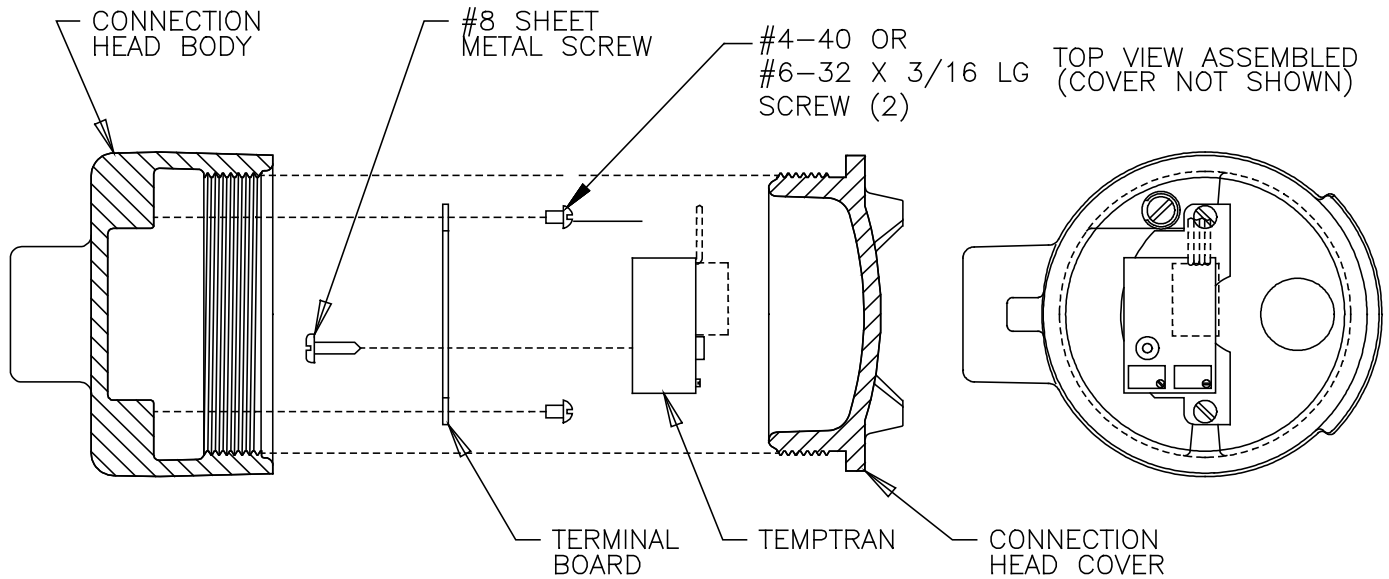

Procedure

The AC101376 mounting kit, rectangular Temptran transmitters and connection head are assembled following the instructions below.

Step	Action
1	Unscrew cover from connection head body.
2	Mount miniature, rectangular Temptran to terminal board using #8 sheet metal screw.
3	Mount Temptran/terminal board assembly to connection head body using #6 × 3/16" long screws.
4	Make necessary wiring connections per Temptran wiring instructions.
5	Screw cover back onto connection head body and close tightly.

Worldwide Headquarters
 7300 Commerce Lane
 Minneapolis, MN 55432
 USA
 Tel: 1.763.571.3121
 Fax: 1.763.571.0927
 sales@minco.com
 www.minco.com

European Headquarters
 Usine et Service
 Commercial, Z.I.
 09310 Aston, France
 Tel: (33) 5 61 03 24 01
 Fax: (33) 5 61 03 24 09

Asia Pacific Headquarters
 20 Science Park Road
 #02-31 Teletech Park
 Singapore Science Park II
 Singapore 117674
 Tel: (65) 6511 3388
 Fax: (65) 6511 3399

ISO 9001:2000 /
 AS9100B

© Minco 2016
 Form 890629-5
 ECO #44105
 Stock #030-2049



Flex Circuits
 Thermofoil™
 Heaters
 Sensors
 Instruments